

TRİGER KAPAK SIKMA MAKİNASI

TEKNİK ÖZELLİKLER

- Makine Şasesi : AISI304
- Kapasite : 2.800 ad/sa
- Ambalaj Yüksekliği : 140 – 300 mm
- Ambalaj Çapı : 40 mm- 100mm
- Ürün Çıkış Hızı : 5 – 30 m/dak.
- Makine Kontrol Ünitesi : LCD
- Çalışma Voltajı : 220V / 50Hz / 3A
- Kontrol Voltajı : 24 VDC
- Ambalaj Özelliği : Şeffaf ve Opak Cam veya Plastik
- Ürün Sensörü : Cisimden Yansımali Optik Sensör
- Konveyör Hız Kontrolü : Frekans Inverteri
- Çalışma Basıncı : 6-8 Bar
- Kontrol Ünitesi : PLC
- Kapak Sıkma Ünitesi : Servo Motor veya Havalı Motor
- Konveyör sistemi : 3 mt.
- Konveyör Motoru : 0.37 kW
- Konveyör Ünitesi : Asetal Bantlı
- Konveyör Genişliği : Ürüne Özel (82mm veya 114mm)

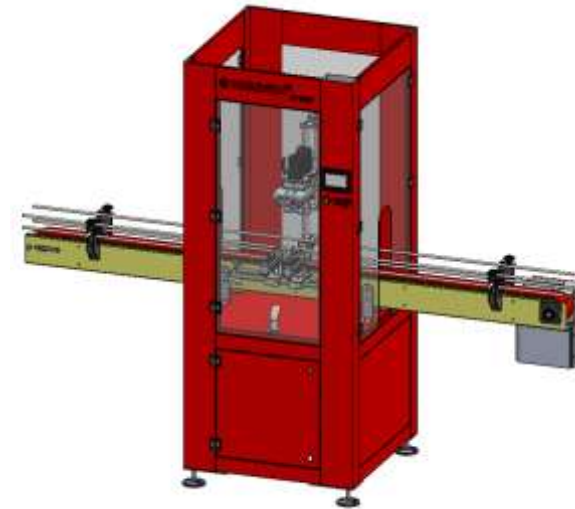



TURKFILL

Mühendislik Makine Sanayi ve Ticaret Ltd.Şti.

TRIGGER CAP CLOSER MACHINE

TECHNICAL SPECIFICATIONS

- Machine Frame : AISI304
- Capacity : 2,800 pcs/h
- Packaging Height : 140 – 300 mm
- Packaging Diameter : 40 mm - 100 mm
- Product Output Speed : 5 – 30 m/min
- Machine Control Unit : LCD
- Operating Voltage : 220V / 50Hz / 3A
- Control Voltage : 24 VDC
- Packaging Material : Transparent and Opaque Glass or Plastic
- Product Sensor : Reflective Optical Sensor
- Conveyor Speed Control : Frequency Inverter
- Operating Pressure : 6-8 Bar
- Control Unit : PLC
- Lid Clamping Unit : Servo Motor or Pneumatic Motor
- Conveyor System : 3 mt
- Conveyor Motor : 0.37 kW
- Conveyor Unit : Acetal Belt
- Conveyor Width : Product Specific (82mm or 114mm)

